



## Powerful laser printing right where you need it.

Don't adapt your packaging line for a printer. The **SmartLase® C600** BOU solution is designed to integrate easily into the most challenging spaces. High-quality, chemical-free, permanent coding on PET bottles, glass, labels, flexible films, inked paper/carton, and coated metals like those found in the beverage industry. You can expect lower operating expenses and exceptional performance in high-speed applications—right where you need it.

## 60-watt BOU solution: Limitless flexibility



### Adaptability and ease of integration

The unit can be configured with up to three elbows and four tubes that come in six standard lengths to meet most installation scenarios. Tubing lengths can be further customized to meet customers needs and can be rotated 360 degrees around their own axis, allowing for installation at the perfect angle.



### Innovative and precise design

Designed to guide the laser beam from the source to the scanning head without a loss of quality of the beam itself. The aluminum elbows are lightweight, while the stainless-steel tubes lend rigidity to the construction.



### Optimizing laser health

Sometimes it's not about tight spaces, rather more about the surrounding conditions, so the BOU allows you to get best performance and life out of your laser printer. It also can place the laser unit at a convenient and easy to access place for periodic maintenance.



### Designed with safety top of mind

Be assured the BOU was designed to uphold MI's rigorous safety standards and adding the BOU to the marking system will not compromise the factory IP55 protection.



Advance flexibility: 6 standard tube lengths to accommodate most applications

# SmartLase® C600 – Beam Orientation Unit (BOU) Integration information

## BOU configurable options

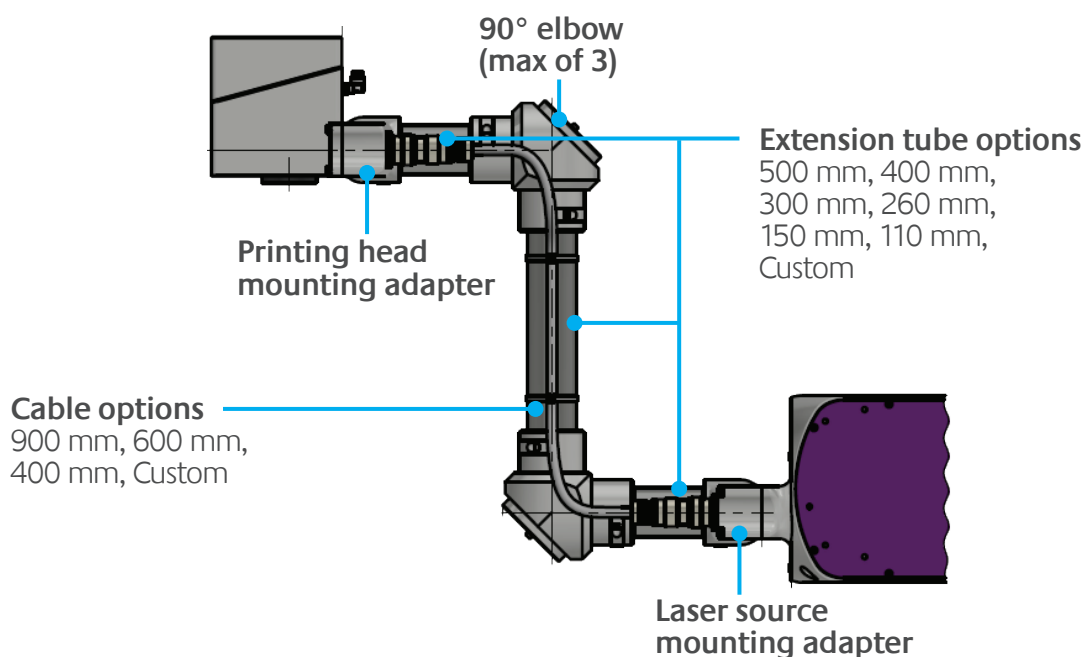

### Application specification

High quality coding up to 150,000 products/hour

Proven robust industrial design with IP55 protection

Efficient extraction system with automatic flow control optimized for high-speed coding (ES500+ solution)

### Accessories

Installation/Service package: set of spare O-rings, fasteners and tube lock

Alignment Tool

Cable Clamp



#### Perfect angle

Tubing has ability to rotate 360° around its own axis. Limitless integration configurations.



#### High-quality coding right where you need it

High-quality, permanent codes anywhere on the line.



#### Faster and longer

Provide optimal working environment to lase at highest production line speeds: up to 150,000 products per hour\*.



#### Easy access for maintenance

Enable easy access for maintenance even in the most complicated and cramped lines.



#### Lower OpEx and greater sustainability

Since there are no consumables or need for external cooling, there is less maintenance and fewer line stoppages.



markem•image

a DOVER company